

# Minimix Laboratory Mixer from EC Engineering

The ECE Minimix is the smallest, lightest, lowest cost jar tester system available. It has been specifically designed for those situations where larger units would be inconvenient or impractical. Its briefcase-sized carrying case has plenty of room for accessories and reagents, and its 12V DC electrical system allows the Minimix to operate anywhere. The four 500 mL sample jars are integrated into a single unit for quick, simple, easy handling.

The Minimix system comes with a 30-day money back guarantee of satisfaction, and a one year warranty.



- Super compact - 14" x 3" base, 7" height
- Lightweight - less than 7 lb, including case and accessories
- Direct paddle speed settings, to 300 rpm
- High intensity mixing
- No manipulation of individual paddles
- Mixer unit locks in place or instantly lifts off jar assembly
- No paddle shaft binding in bearings
- Large paddles minimize floc breakup
- Improved, integrated square jar assembly for quick and easy handling
- Clear sheet acrylic jar material for good visual observation of samples
- 500 mL jars minimize sample volumes needed for off-site work

# Minimix Laboratory Mixer

The illustration shows the main features of the ECE Minimix system. It has two main parts - the mixer unit, and the integrated four-compartment jar assembly.

The mixer unit includes the main housing (1), drive system housing (2), paddles (3), power on/off switch (4), motor speed control dial (5), a latching system (6) to lock the mixer unit to the jar assembly, and a power jack (7) on the rear of the unit.

The jar assembly (8) is constructed from clear acrylic sheet and contains four 500 mL sample compartments (9). Each sample compartment has a graduation mark (10) and a sampling stopcock (11) which threads into the jar wall. When subsurface sampling is not required, the stopcocks can be replaced with caps to reduce the chance of breakage and to make handling a little easier. Spare jar assemblies and fittings are available separately.

The Minimix can be powered from any 12V DC supply, through a standard power jack on the rear of the unit. Normally, this power would be provided by the 120V AC / 12V DC plug-in wall transformer (12) supplied with the system.

In use, the jars are filled with water samples and the mixer unit is simply placed on top of the jars. The mixer unit locks into place, and the whole assembly can be lifted and moved about if desired. There is no need to manipulate individual paddles, and no shaft binding resulting from water being deposited in bearings as paddle shafts are lifted through them.

The desired mixer speed is selected on the control panel dial. The speed control system is configured so that the dial scale is expanded towards the lower end of the speed range, which allows easier and more accurate adjustments at the low speeds (20 to 100 rpm) where most jar testing work is carried out. Speed adjustment accuracy using this direct-dial speed control is more than adequate for most jar testing applications.

After selecting the mixer speed, the mixer is started, chemicals are added, and the coagulation / flocculation sequence is carried out in the normal way. At the end of the flocculation period, the paddles are stopped and the floc is allowed to settle. The mixer unit can be lifted out of the sample jars for this phase (it unlocks instantly) or left in place.

After the desired settling periods, subsurface sampling may be carried out using the miniature stopcock-based sampling ports provided on each jar compartment.

The Minimix is constructed from the same high-quality materials used in our other systems - epoxy coated PVC and aluminum housings, stainless steel paddles and shafts, long-lasting nylon gears, lifetime-lubricated oil-impregnated bronze bearings, and clear acrylic jar assembly.

The system is supplied in a rugged, lightweight molded plastic carrying case. The case can hold the mixer unit, jar assembly, and power supply with a useful amount of space left over. This space

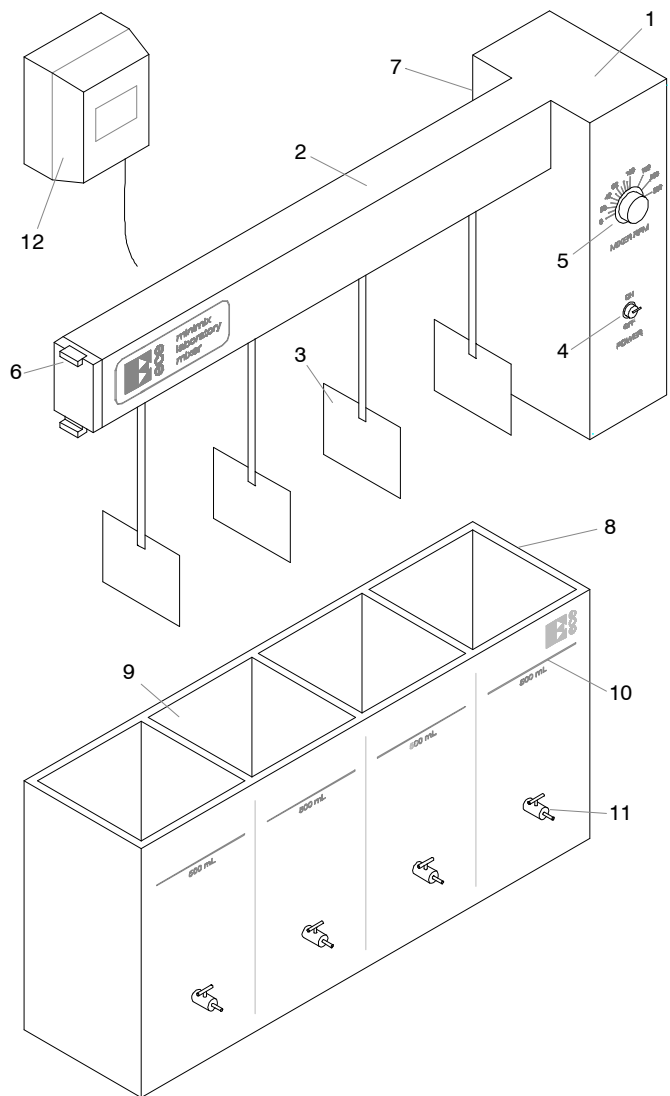

can be used for storage and transportation of other frequently used items such as chemical reagent bottles, dosing syringes, sample containers, or other equipment, to provide a totally self-contained jar testing system.

The carrying case is about the size of a small briefcase, and weighs less than 7 lb (3 kg) including all Minimix system units and typical accessories.

As with all ECE equipment, the Minimix system comes with a 30-day money-back guarantee of satisfaction, and a one-year warranty. Delivery is usually ex stock, with same or next day shipping.

Spare parts, service, and technical advice are readily available in North America.

For more information, detailed specifications, and current pricing, please visit us at [www.ecengineering.net](http://www.ecengineering.net).



## EC Engineering

6223 - 186 Street, Edmonton, Alberta, Canada T5T 2T3  
Phone 780.487.0249 Fax 780.487.6883 [www.ecengineering.net](http://www.ecengineering.net)